



Installation instructions, accessories

Volvo Car Corporation Gothenburg, Sweden

Instruction No	Version	Part. No.
31373262	1.0	31359467

Towbar, hitch



Installation instructions, accessories

Volvo Car Corporation Gothenburg, Sweden

Equipment

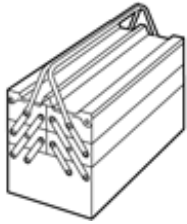

IMG-345497



IMG-239664

**Nm
lbf.ft**



IMG-239660



IMG-240693



IMG-256903

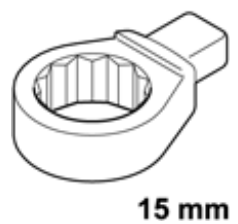

IMG-282923

15 mm

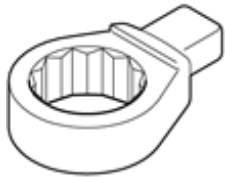

IMG-282924

13 mm

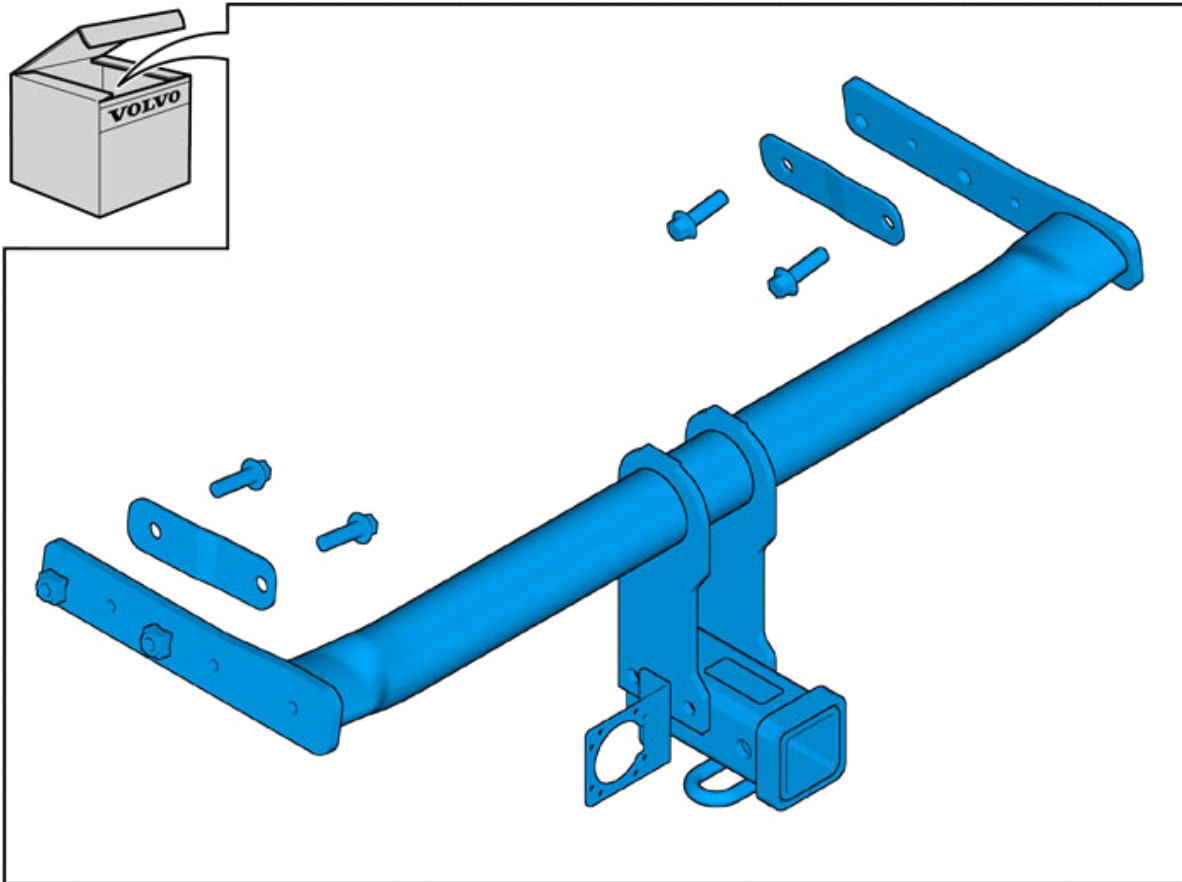

IMG-364299



Installation instructions, accessories

Volvo Car Corporation Gothenburg, Sweden

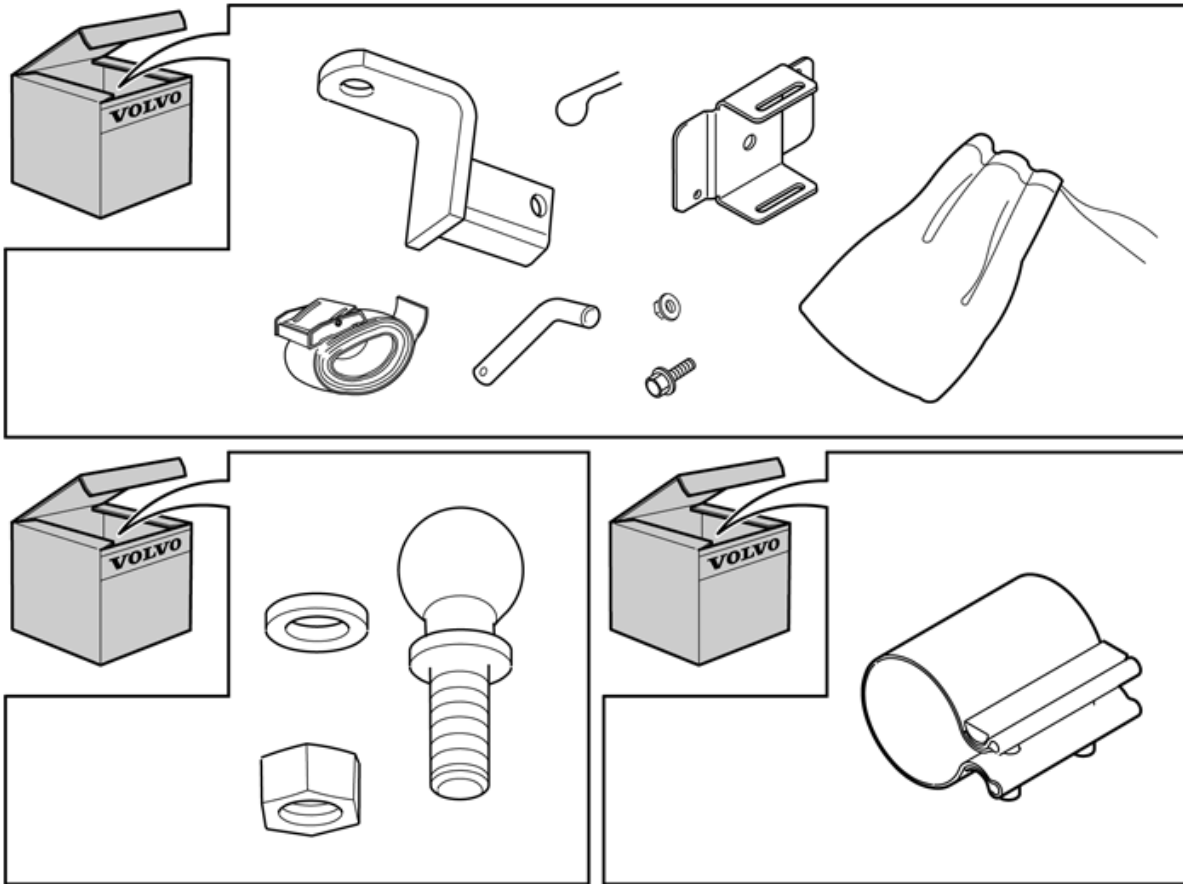

IMG-364309



Installation instructions, accessories

Volvo Car Corporation Gothenburg, Sweden

INTRODUCTION

Read through all of the instructions before starting installation.

Notifications and warning texts are for your safety and to minimise the risk of something breaking during installation.

Ensure that all tools stated in the instructions are available before starting installation.

Certain steps in the instructions are only presented in the form of images. Explanatory text is also given for more complicated steps.

In the event of any problems with the instructions or the accessory, contact your local Volvo dealer.

1

Applies to vehicles with twin rear silencers

Note!

To facilitate access when tightening the towbar member, the exhaust system must be cut at the marking according to the instructions. It is important to use this method, otherwise there is a risk of damaging the exhaust system if the silencers are forced down for example.

2

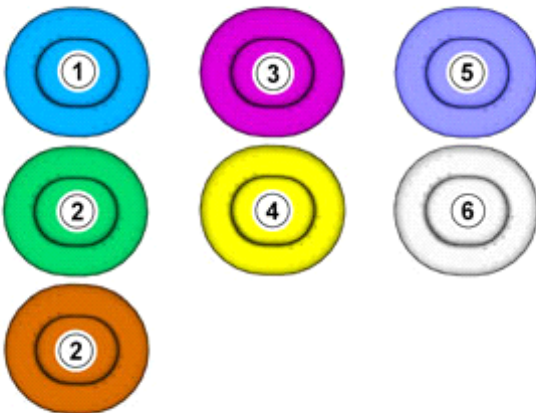

IMG-363036

Note!

This colour chart displays (in colour print and electronic version) the importance of the different colours used in the images of the method steps.

1. Used for focused part, the part that you are to do something with.
2. Used as extra colors when you need to show or differentiate additional parts.
3. Used for attachments that are to be removed/installed. May be screws, clips, connectors, etc.
4. Used when the component is not fully removed from the vehicle but only hung to the side.
5. Used for standard tools and special tools.
6. Used as background color for vehicle components.



Installation instructions, accessories

Volvo Car Corporation Gothenburg, Sweden

3

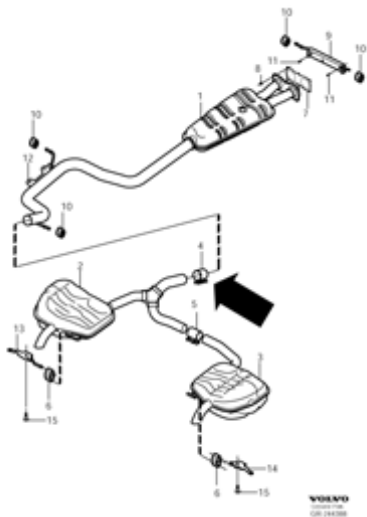

IMG-261524

Note the engine version of the car.

Enter VIDA under:

Engine with mountings/

Intake and exhaust system/

Silencers and exhaust lines/

Silencer rear.

Order exhaust clamp for joining the exhaust system.

4

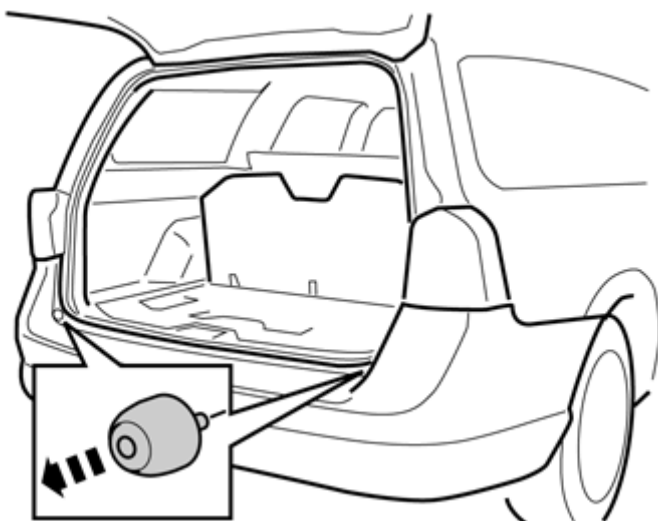

IMG-259683

Removal

Unscrew the two rubber stops.



Installation instructions, accessories

Volvo Car Corporation Gothenburg, Sweden

5

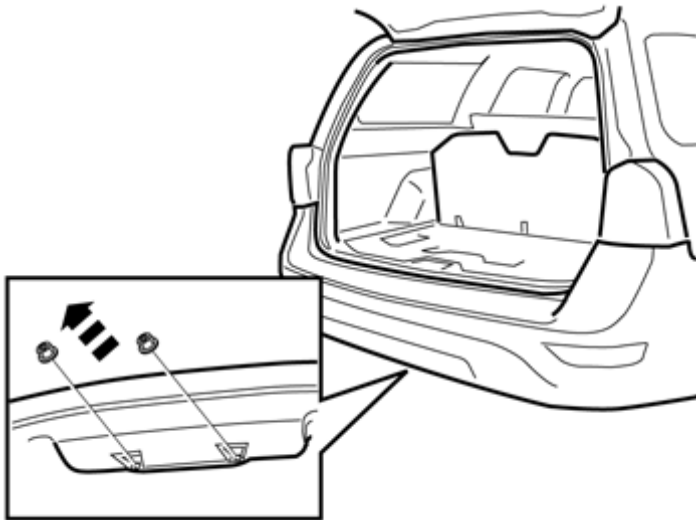

IMG-259753

Remove the plastic nuts.

6

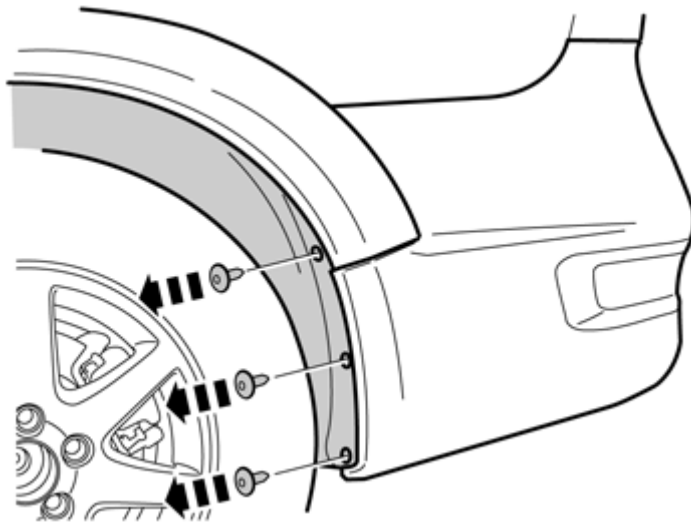

IMG-259755

Remove the three screws.

7

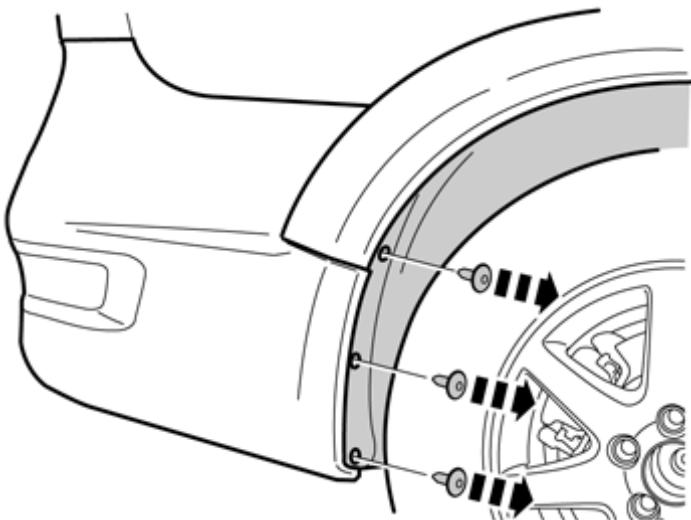

IMG-259754

Remove the three screws.



Installation instructions, accessories

Volvo Car Corporation Gothenburg, Sweden

8

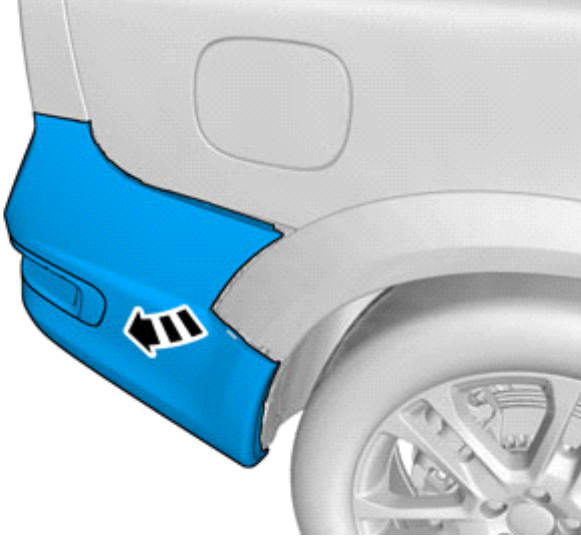

IMG-379389

Repeat the operation on the other side.

9

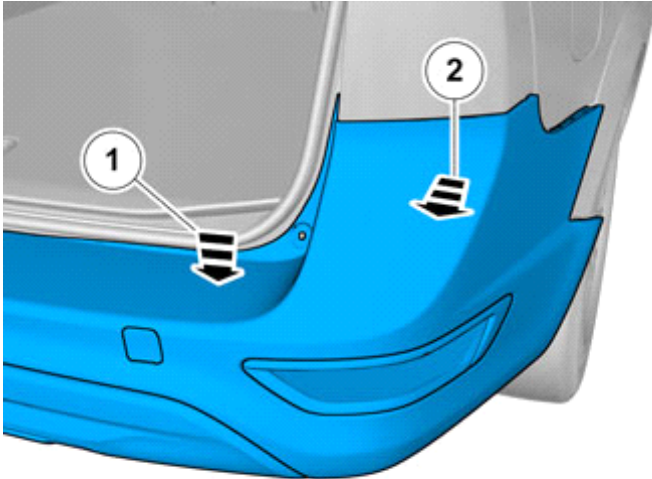

IMG-379404

Caution!

Press the bumper casing down when removing, so as not to damage the rear lights.

Note!

This step is easier with two people.

Repeat the operation on the other side.

10

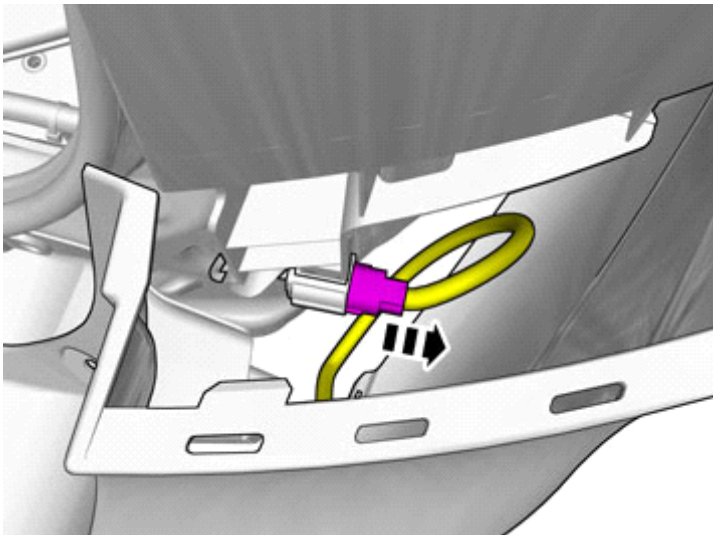

IMG-379386

Note!

This step is easier with two people.

Release the connector's catch.

Unplug the connector.



Installation instructions, accessories

Volvo Car Corporation Gothenburg, Sweden

11

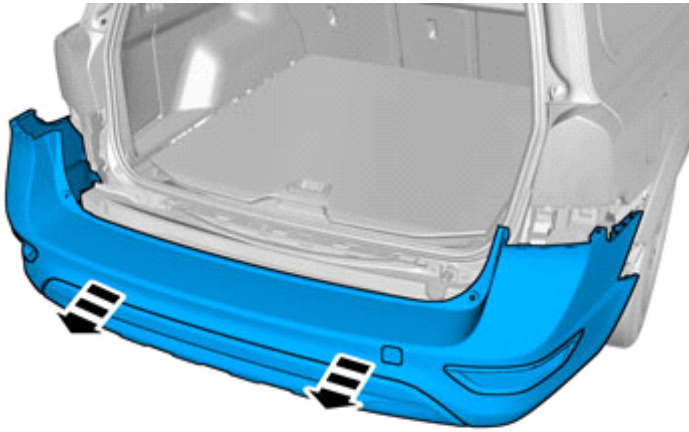

Caution!

Place the bumper cover on a suitable surface.

Note!

This step is easier with two people.

IMG-379405

12

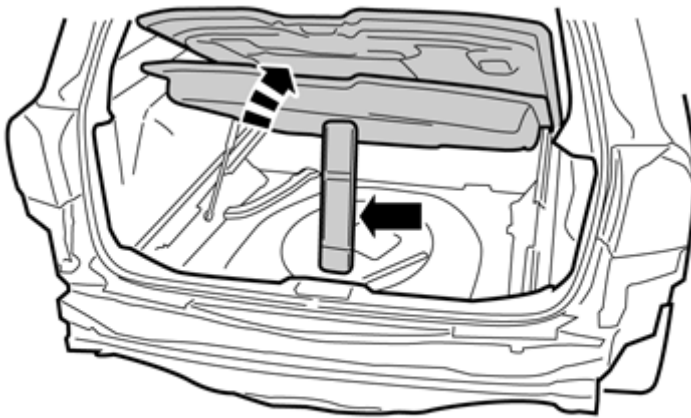

Lift up the cargo floor and load base plate. Place a support under the base plate.

IMG-261414



Installation instructions, accessories

Volvo Car Corporation Gothenburg, Sweden

13

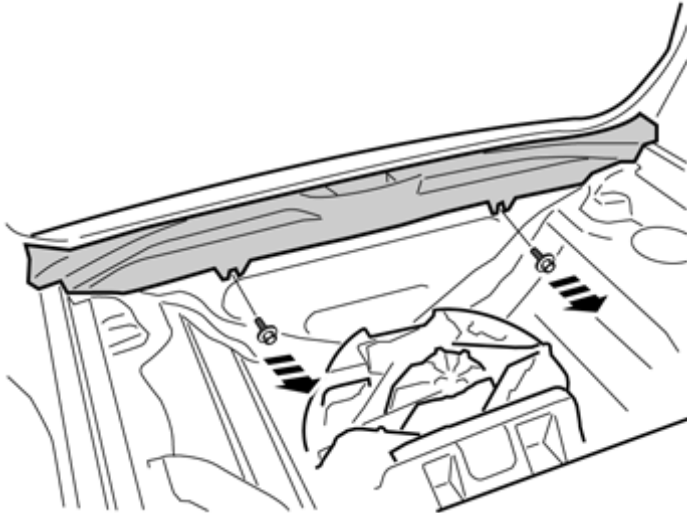

IMG-259759

Remove the screws.

14

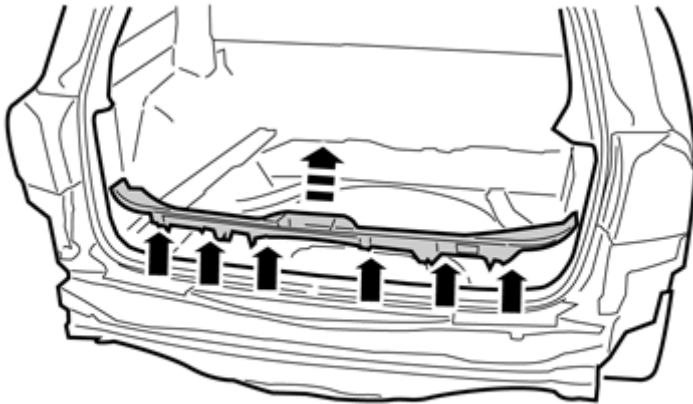

IMG-259760

Carefully pull off the boot lid's sill panel, it is secured by six clips.

15

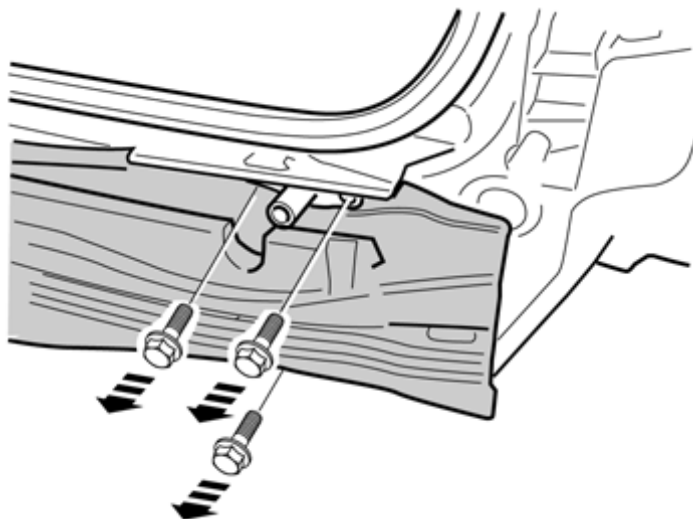

IMG-259761

Remove the screws in the collision member on both sides.



Installation instructions, accessories

Volvo Car Corporation Gothenburg, Sweden

16

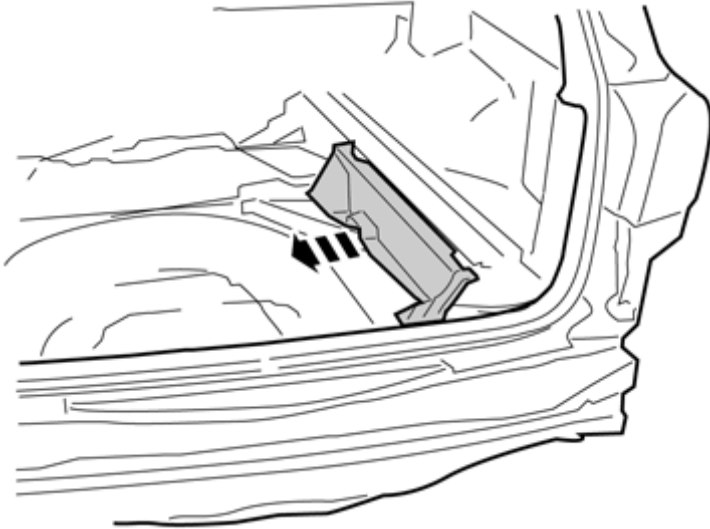

IMG-377019

Remove the panel.

17

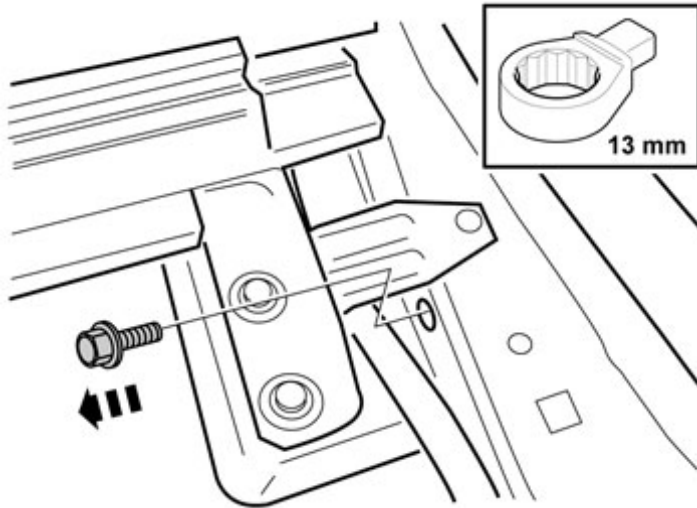

IMG-377020

Remove the screw for the towing eyelet's mounting on the right-hand inside of the rear crossmember. Unscrew it enough that the collision member can be removed.

Note!

Do not damage the cable harness that is there.

18

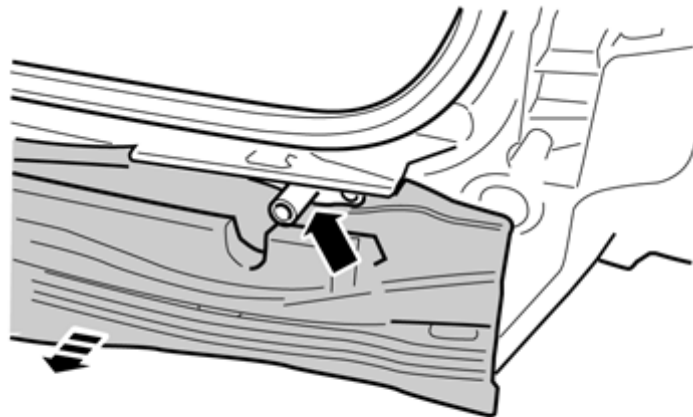

Remove the collision member.

IMG-259763



Installation instructions, accessories

Volvo Car Corporation Gothenburg, Sweden

19

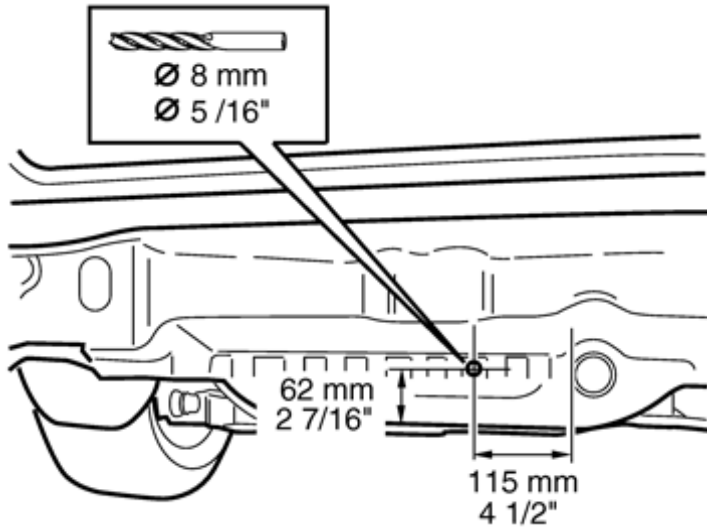

IMG-260410

Accessory installation

Applies to vehicles without spare wheel

Note!

Check that there are no cable harnesses on the inside that obstruct the hole drilling process.

Measure and make markings for making holes for the screw for the towing ball cradle.

Pre-drill using a small drill bit. Drill out the hole to **Ø 8 mm (5/16")**.

Deburr the edges of the hole, apply rustproofing agent and remove the drill swarf.

20

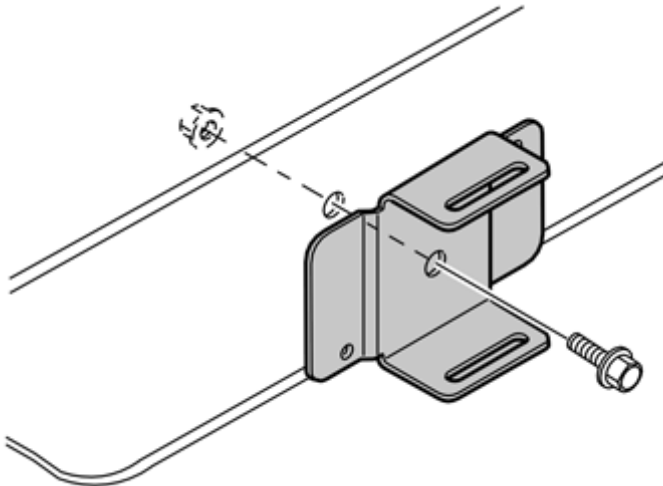

IMG-226142

Install the holder on the inside of the rear crossmember, and tighten it in using a screw and nut from the kit. Torque tighten to **10 Nm (7.5 lbf.ft.)**.



Installation instructions, accessories

Volvo Car Corporation Gothenburg, Sweden

21

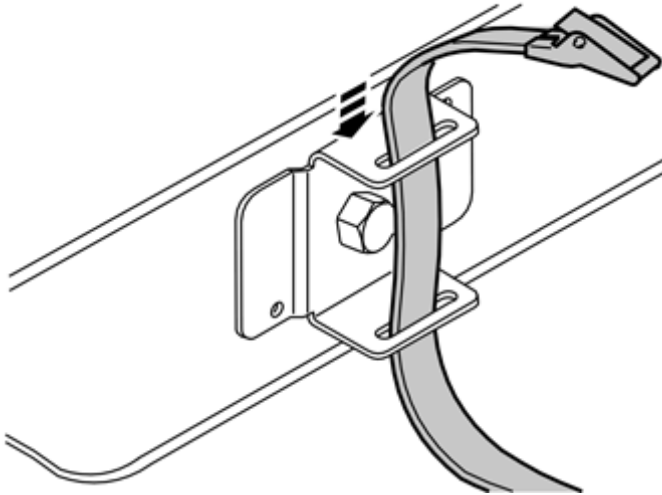

IMG-226143

Take the strap and storage bag from the kit.

Thread the strap in the holder.

22

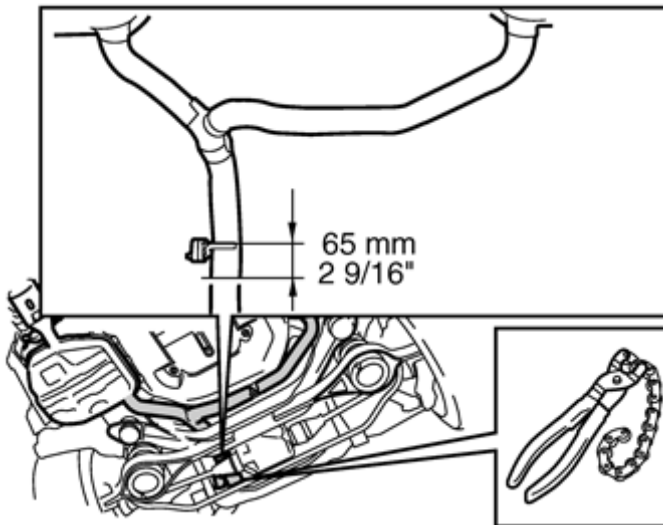

IMG-260845

Applies to vehicles with AWD

Cut off the exhaust pipe with the pipe cutter according to the diagram. The cutting location is marked by a small indentation on the underneath of the pipe.



Installation instructions, accessories

Volvo Car Corporation Gothenburg, Sweden

23



IMG-260846

Remove the rear rubber mounting at the final drive.

24

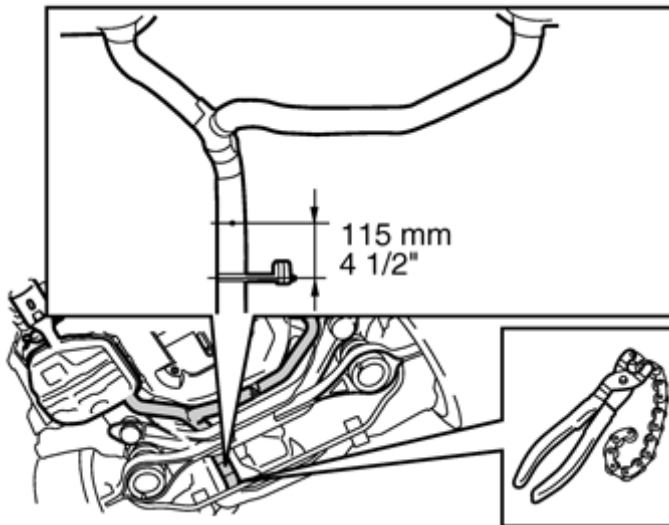

IMG-260847

Applies to vehicles with 2WD

Cut off the exhaust pipe with the pipe cutter according to the diagram. The cutting location is marked by a small indentation on the underneath of the pipe.



Installation instructions, accessories

Volvo Car Corporation Gothenburg, Sweden

25

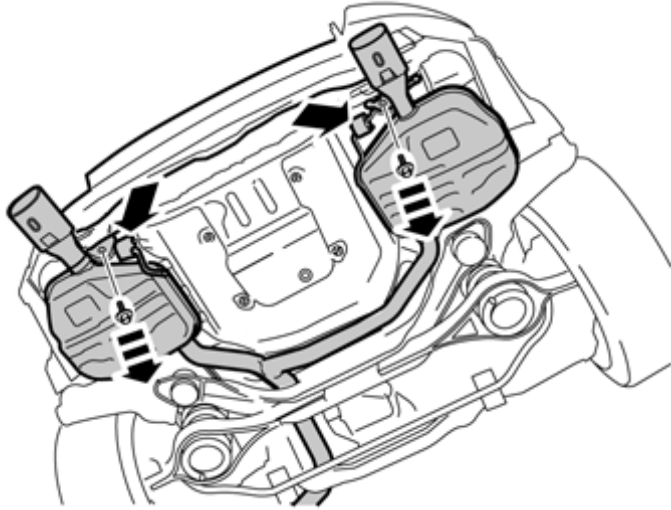

IMG-259825

Applies to all vehicles

Remove the screws from the rear mountings of the silencers.

Remove the silencers from the body.

Hint

Get help from a colleague for this procedure.

26

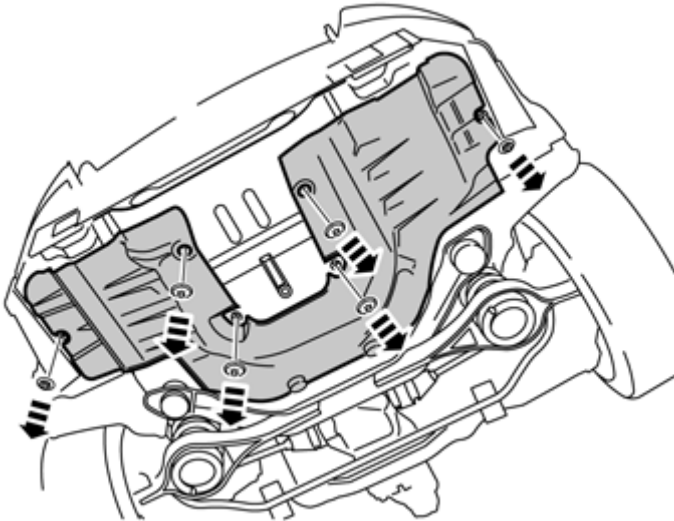

IMG-260849

Remove the six clips from the radiated heat shield.

27

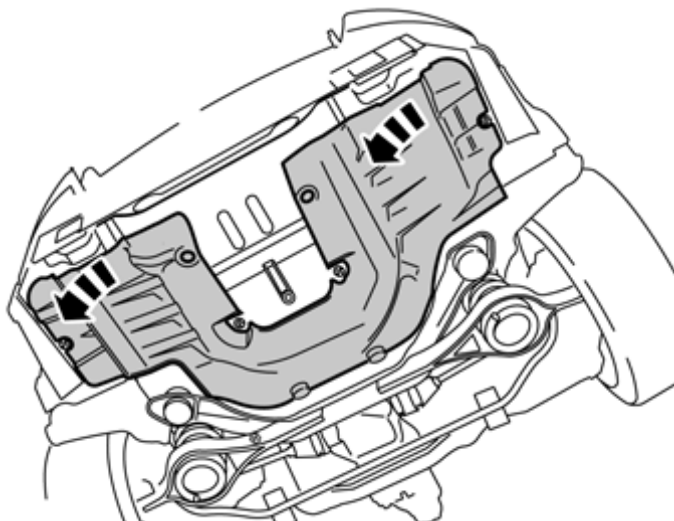

IMG-260850

Fold the radiated heat shield down to access the inside of the side members.



Installation instructions, accessories

Volvo Car Corporation Gothenburg, Sweden

28

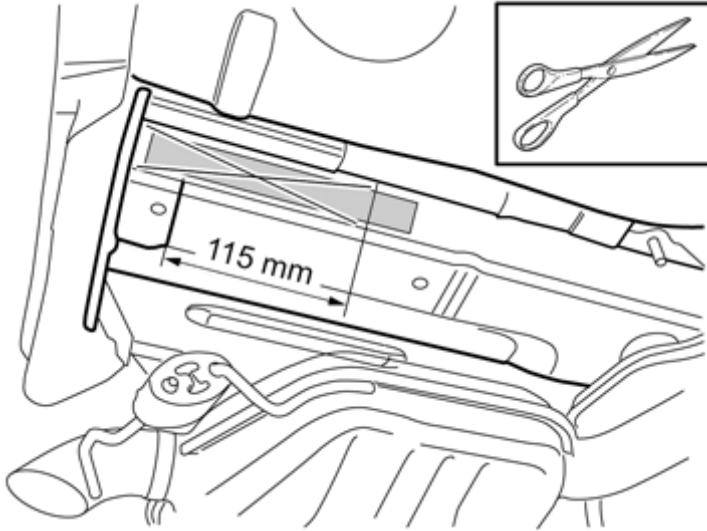

IMG-364281

Remove the last part of the cover on the insides of the side members.

29

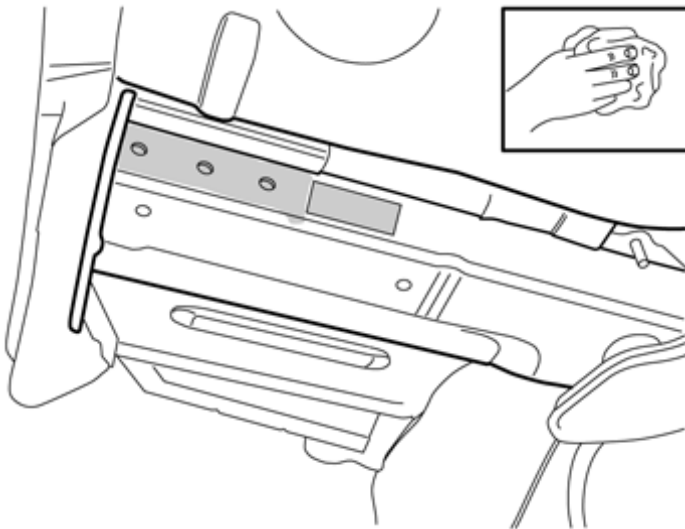

IMG-260852

Thoroughly clean away splashes of underseal, putty or dirt from the plate surfaces on the insides of the side members where the reinforcements shall be located.

30

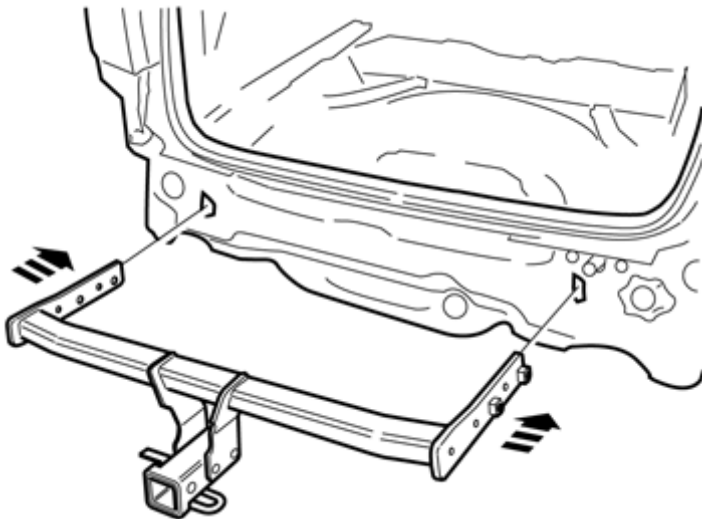

IMG-261098

Check that the contact surfaces inside the side members are clean. If not, clean them opposite where the towing member's side plates shall be tightened.

Take the towing member from the kit and insert the two side plates in the holes in the rear edge of the side members.



Installation instructions, accessories

Volvo Car Corporation Gothenburg, Sweden

31

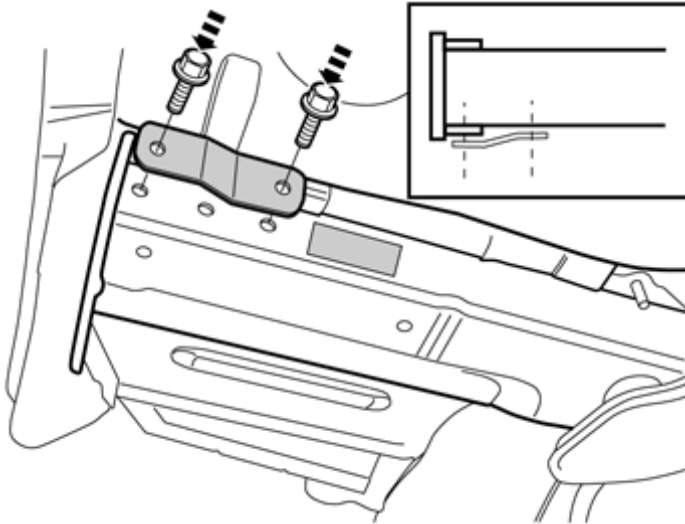

IMG-260853

Take screws and reinforcements from the kit. Request the assistance of a colleague to hold and adjust the position of the towing member's weld nuts.

Note!

Ensure that the reinforcement bar is correctly positioned (see small image).

Tighten the screws alternately on both sides.

32

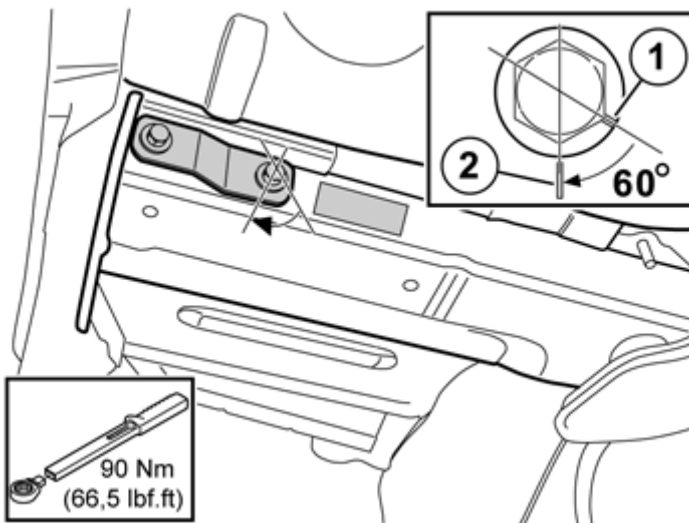

IMG-261123

Torque tighten the screws to **90 Nm (66.5 lbf.ft.)** and angle tighten to **60°**. There may be occasions that a protractor cannot be used on the torque wrench when angle-tightening joints in confined spaces. Instead use a hex screw head to determine the angle.

Make a mark on the screw head flange (1).

Make another mark (2) in the side member or reinforcement bar.

Now tighten the screw so that the screw head marking (1) lines up with the marking (2) on the side member/reinforcement bar.

Repeat for all screws.



Installation instructions, accessories

Volvo Car Corporation Gothenburg, Sweden

33

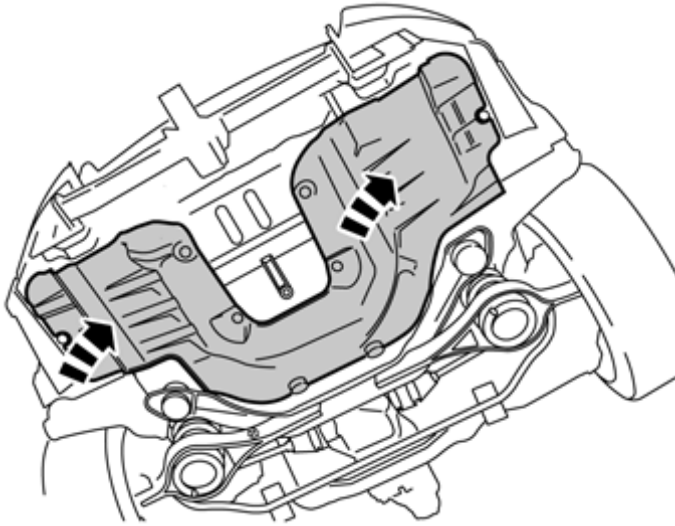

IMG-260855

Installation

Reinstall the heat shield.

34

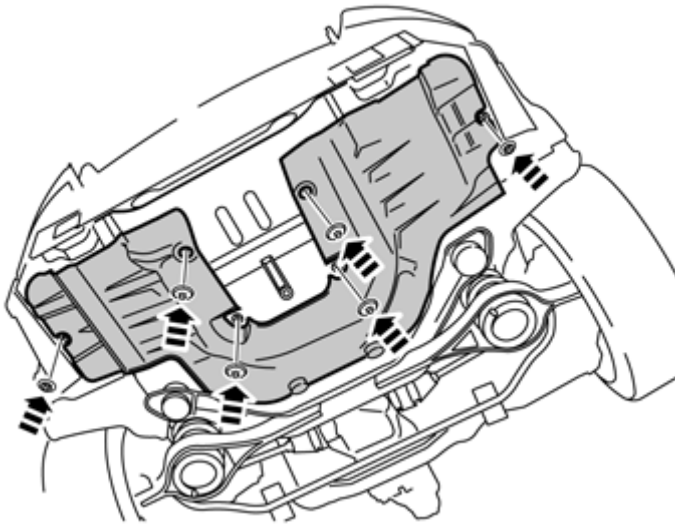

IMG-261083

Reinstall the clips.

35

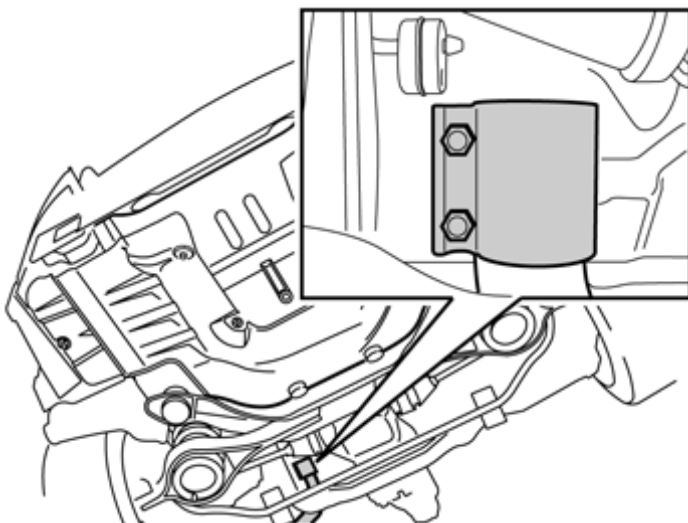

IMG-282943

File down the edges of the exhaust pipes.

Take a new exhaust clamp and thread it over the exhaust pipe on the car.



Installation instructions, accessories

Volvo Car Corporation Gothenburg, Sweden

36

Position the clamp so that the joint is in the middle. Make a mark at the lower edge using a pen.

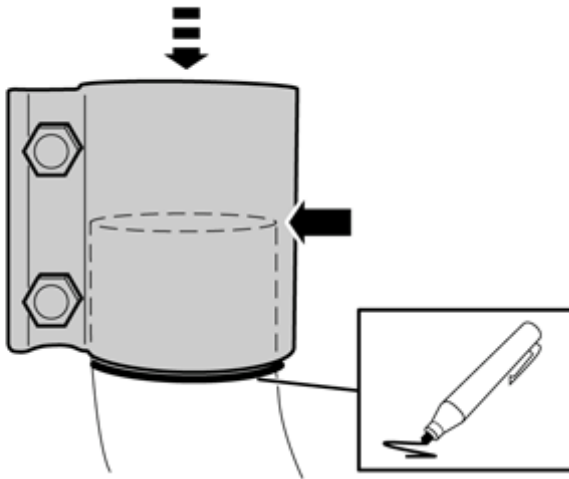

IMG-282946

37

Request the assistance of a colleague, raise and reinstall the silencers with exhaust pipe in the exhaust clamp.

Refit the mountings for the silencers. Torque tighten the screws to **50 Nm (37 lbf. ft.)**.

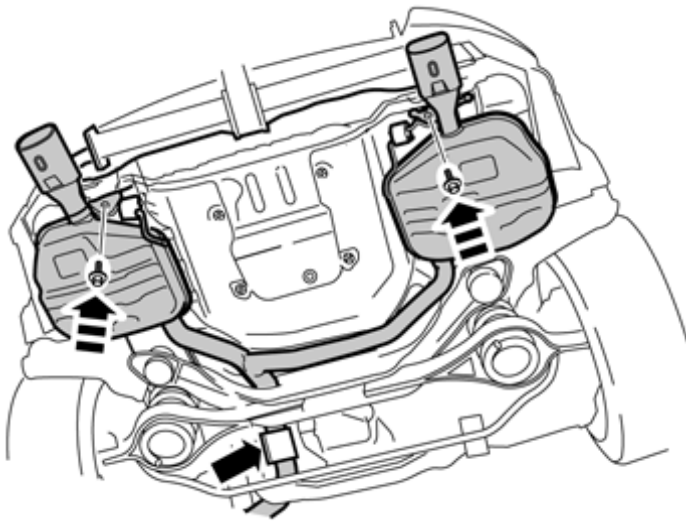

IMG-282963

38

Reinstall the rear rubber mounting at the final drive.



IMG-260865



Installation instructions, accessories

Volvo Car Corporation Gothenburg, Sweden

39

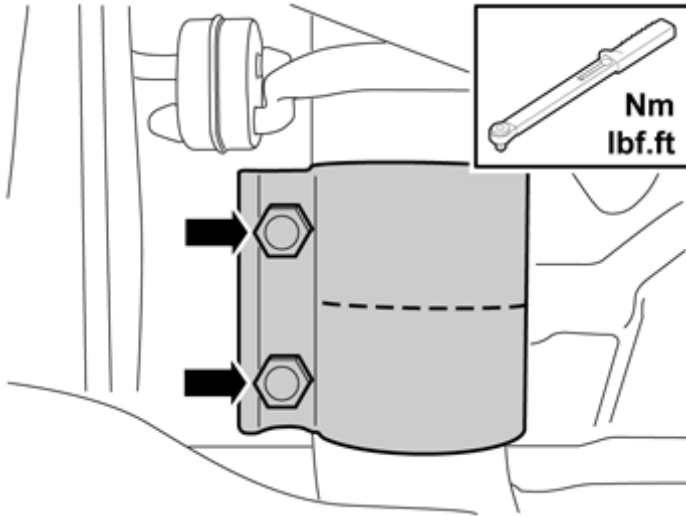

IMG-282964

Position the exhaust clamp as illustrated using the marking made previously.

Tighten the nuts to **50 Nm (37 lbf.ft.)**.

Note!

Check for exhaust gas leaks.

40

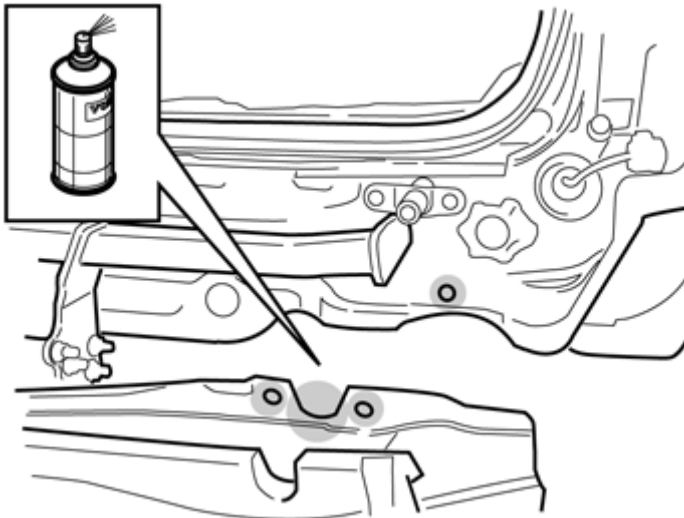

IMG-259875

Rust proof the marked bare sheet surfaces on the collision member, the mounting lug for the towing eyelet bracket as well as the rear side members on the left and right-hand side.



Installation instructions, accessories

Volvo Car Corporation Gothenburg, Sweden

41

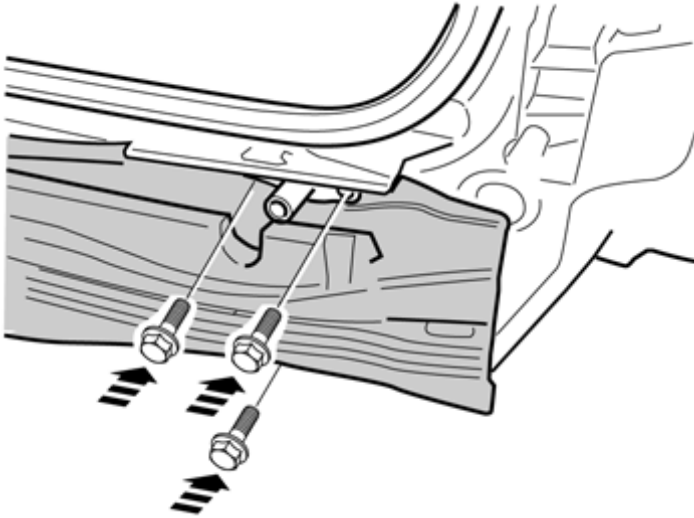

IMG-259876

Reinstall the collision member with bracket to the towing eyelet and tighten the screws on both sides (seven) to **48 Nm (35.4 lbf.ft.)**.

Note!

Do not damage the cable harness that is on the towing eyelet's inner screw.

42

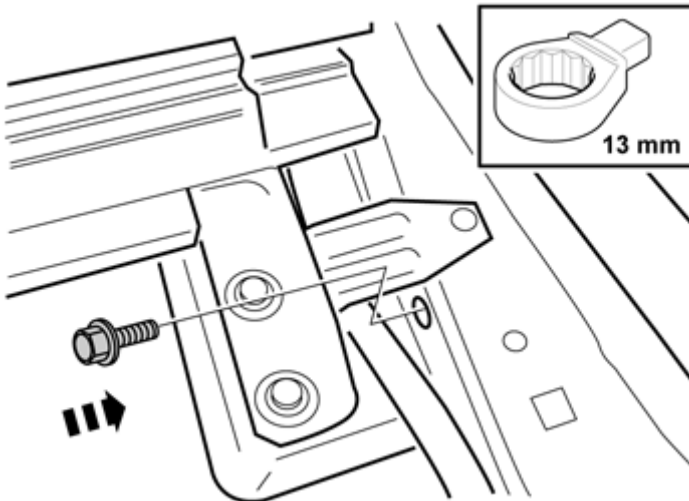

IMG-282983

To torque tighten the towing eyelet's inner screw, use 13 mm plugin tool for the torque wrench.

Note!

Do not damage the cable harness that is on the towing eyelet's inner screw.

43

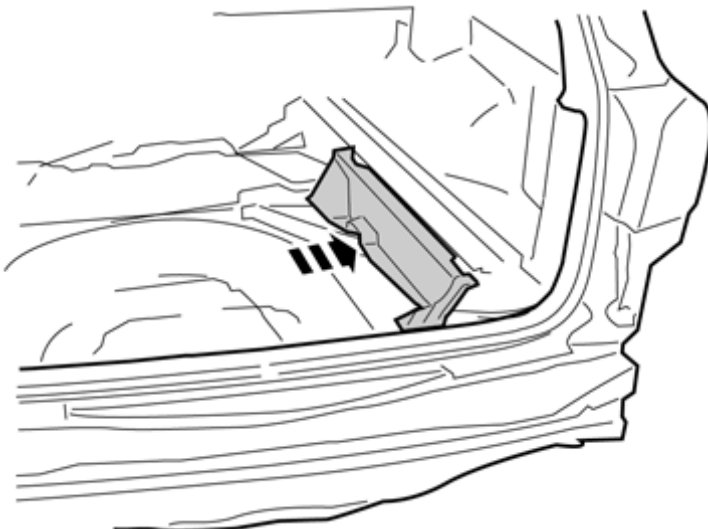

IMG-364322

Reinstall the panel.



Installation instructions, accessories

Volvo Car Corporation Gothenburg, Sweden

44

Reinstall the panel.

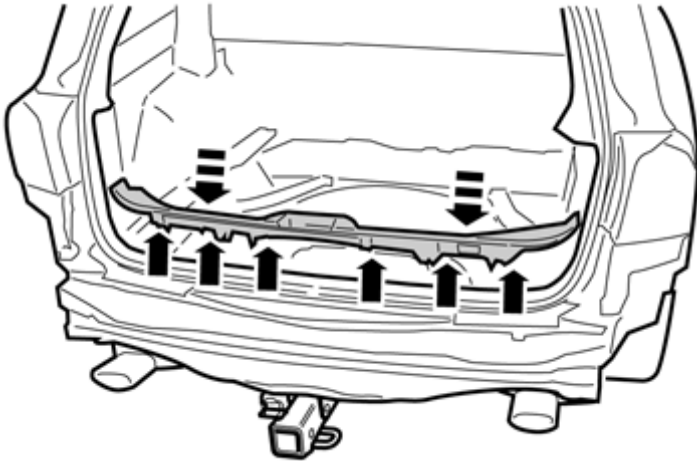

IMG-261101

45

Remove the skid plate from the bumper cover.

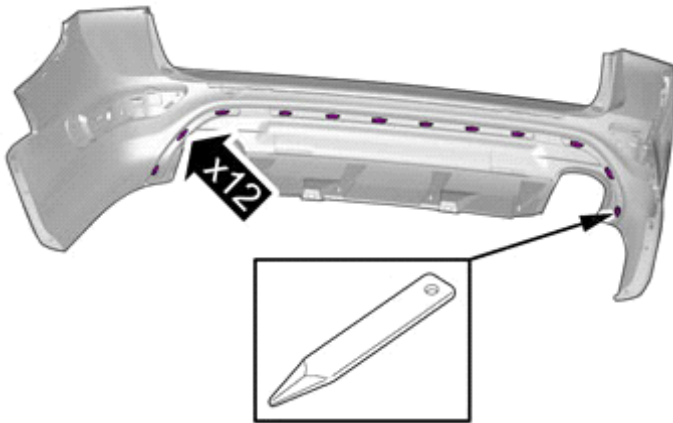

IMG-377452

46

Locate the relevant markings on the bumper cover.

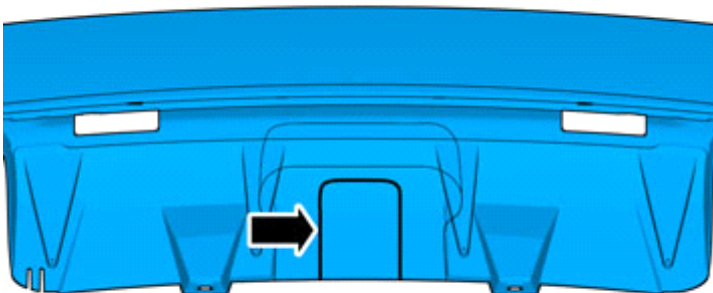

IMG-377459



Installation instructions, accessories

Volvo Car Corporation Gothenburg, Sweden

47

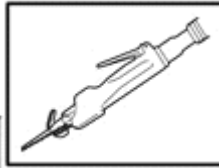

Cut out following the markings.

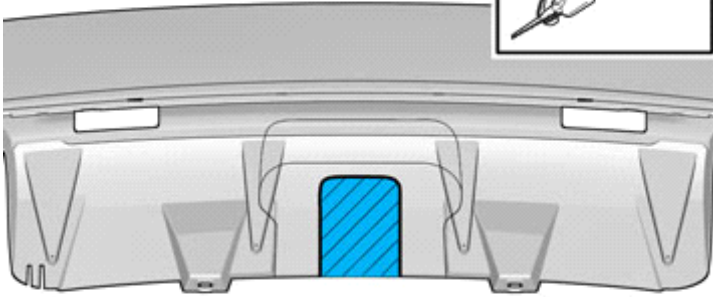

IMG-377460

48

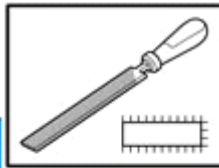

File down the edges.

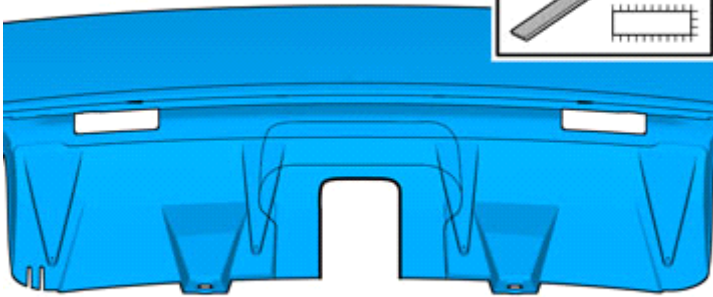

IMG-377461



Installation instructions, accessories

Volvo Car Corporation Gothenburg, Sweden

49

Locate the relevant markings on the skid plate.

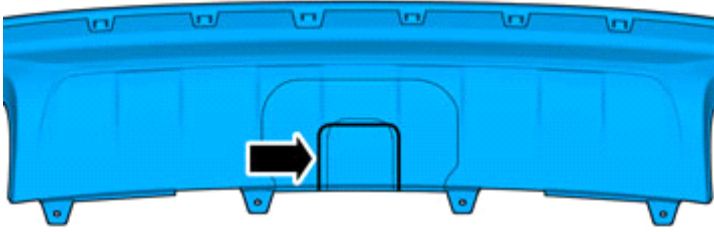

IMG-377462

50



Apply tape as markings on the opposite side.

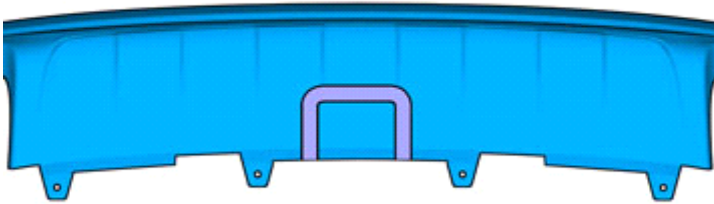

IMG-377466

51

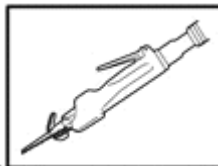

Cut out following the markings.

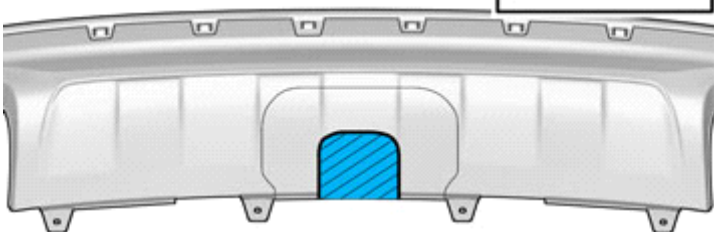

IMG-377464



Installation instructions, accessories

Volvo Car Corporation Gothenburg, Sweden

52

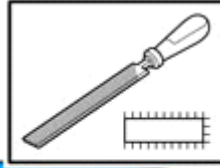

File down the edges.

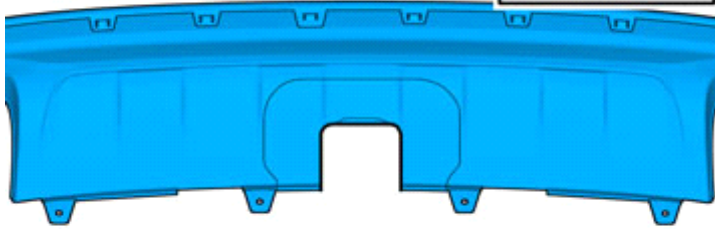

IMG-377465

53

Install the tow bar's connector with cable harness according to the applicable installation instructions.

54

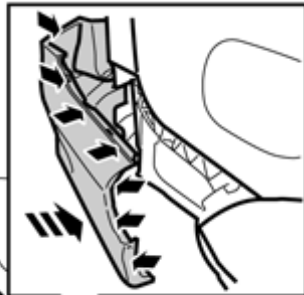

Installation

Connect the connector to the rear parking assistance, if applicable. Reinstall the bumper cover. Ensure that all hooks and guides engage.

Note!

Request the assistance of a colleague when carrying out this procedure to prevent damaging the bumper cover.

IMG-261125



Installation instructions, accessories

Volvo Car Corporation Gothenburg, Sweden

55

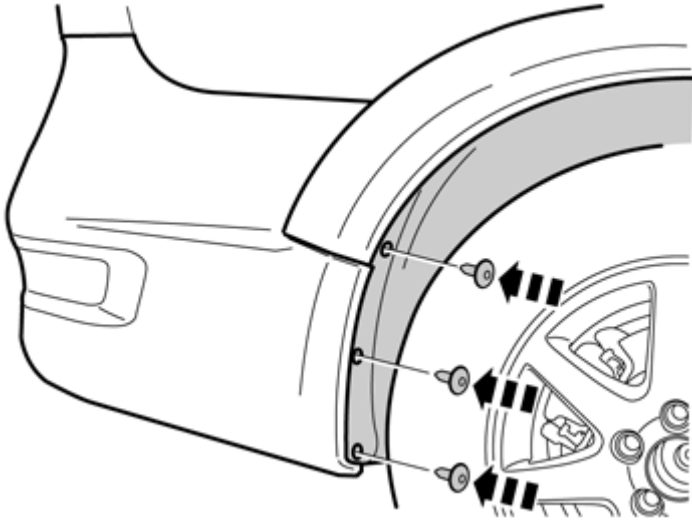

Reinstall the screws.

IMG-259891

56

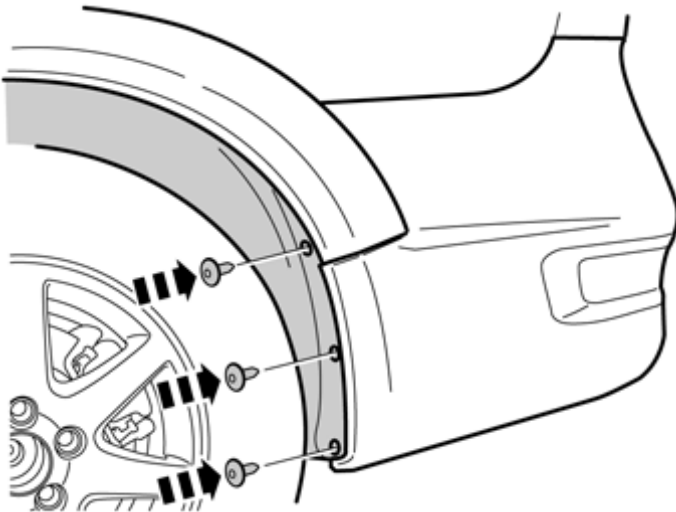

Reinstall the screws.

IMG-259892

57

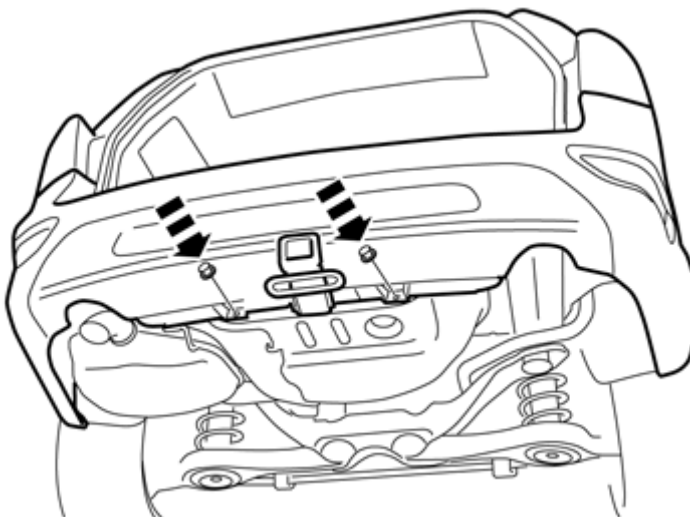

Reinstall the nuts.

IMG-261127



Installation instructions, accessories

Volvo Car Corporation Gothenburg, Sweden

58

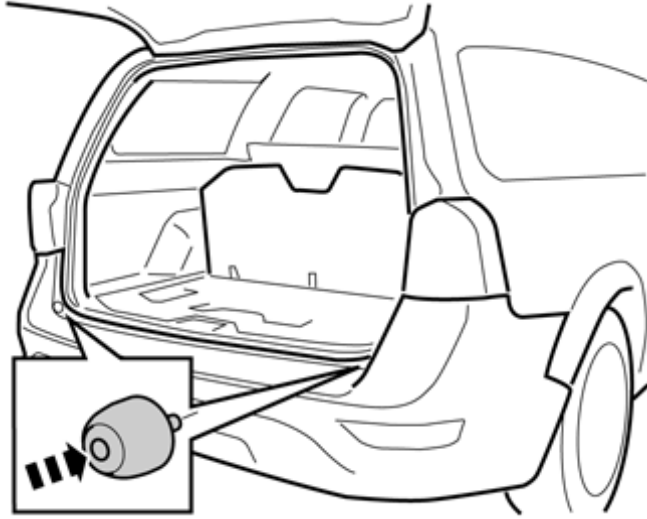

IMG-259894

Screw in the two rubber stops.

59

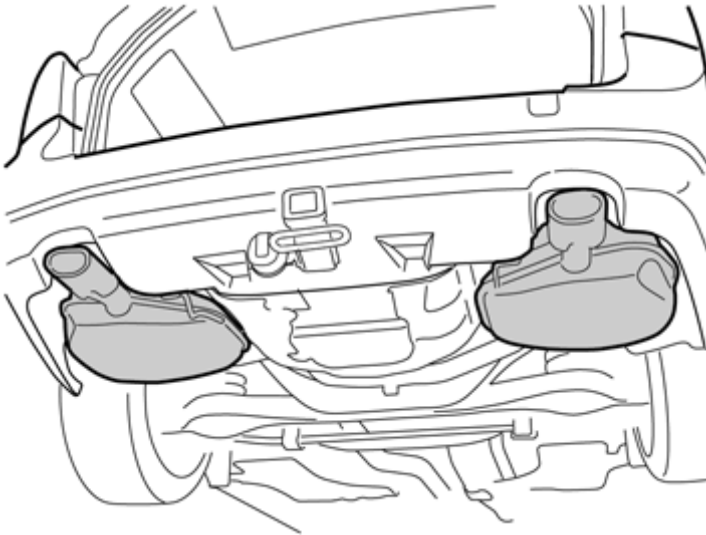

IMG-364326

Check that the end pipes of the silencers are correctly centered in the bumper cover cutout. If necessary, adjust the mountings at the rear silencer at the cutout point or at the joint between the silencer if the car if applicable.

60

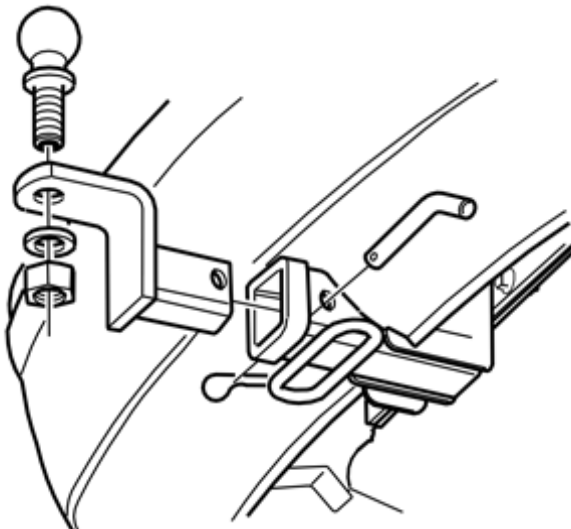

J8903208

Remove the cover

Take the ball holder, ball, washer, nut, lock bolt and locking pin from the kit.

Insert the ball cradle in the towing member's square bracket until the holes in the ball holder and square bracket correspond.

Slide the locking bolt into the hole.

Lock the other side using the locking pin.

Position the ball in the hole on the ball holder.

Install the washer and nut. Torque tighten to **244 Nm (180 lbf.ft.)**.



Installation instructions, accessories

Volvo Car Corporation Gothenburg, Sweden

61

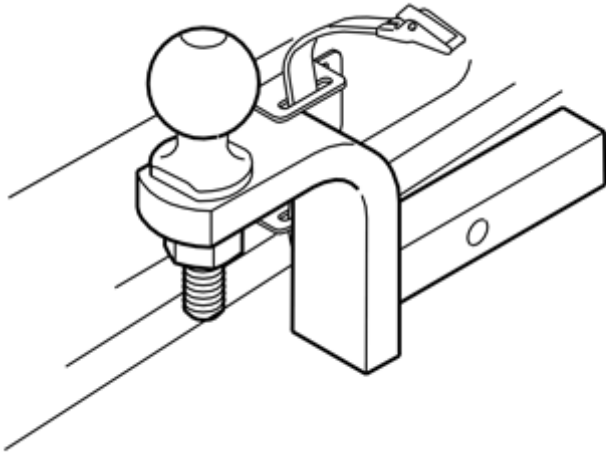

IMG-228976

Applies to vehicles without spare wheel

Remove the bag from the kit, put the towball inside and tie it up.

Wind the long strap twice around the bag and tighten firmly.

62

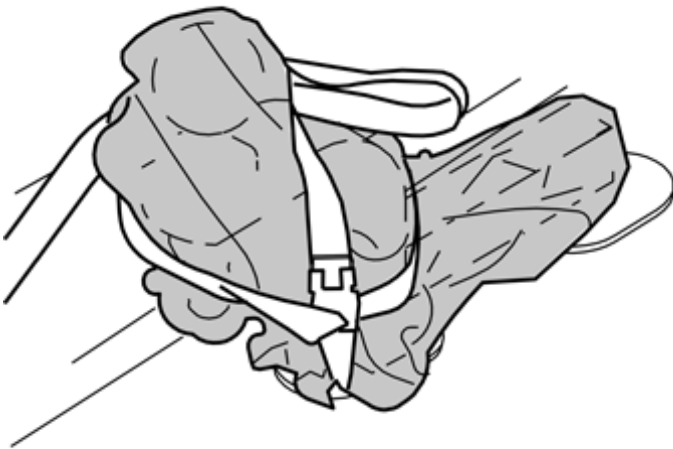

IMG-231220



Installation instructions, accessories

Volvo Car Corporation Gothenburg, Sweden

63

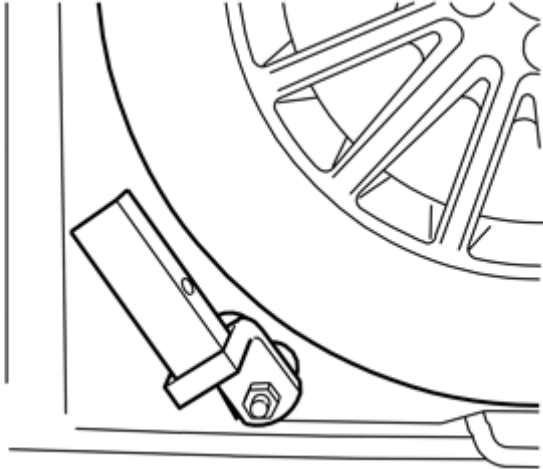

IMG-228980

Applies to vehicles with spare wheel

Remove the bag from the kit, put the towball inside and tie it up.

Wind the long strap twice around the bag and once around the wheel and tighten firmly.

64

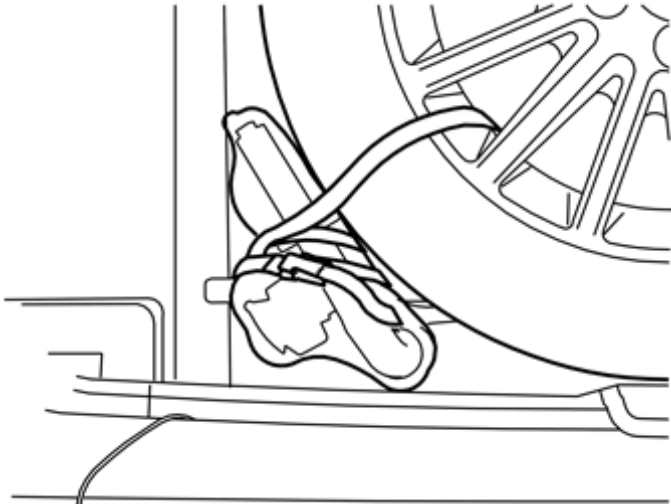

IMG-226150

65

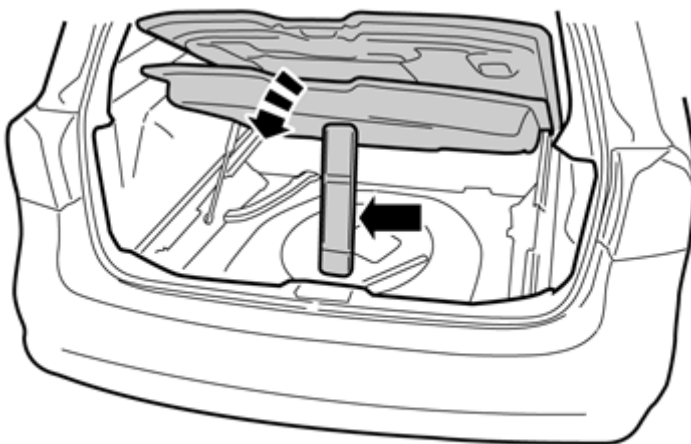

IMG-261415

Applies to all vehicles

Reinstall the base plate and load floor.



Installation instructions, accessories

Volvo Car Corporation Gothenburg, Sweden

66

Press the protective cover into the towing member's square bracket.

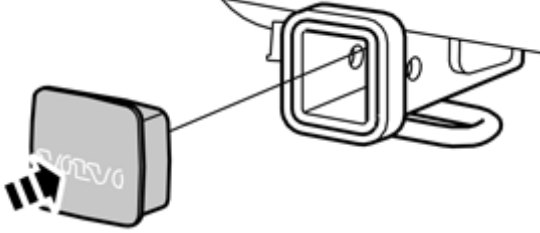

IMG-228982